

Precision plus power equals quality

Band sawing machines

750 x 500 mm
or 1,010 x 500 mm

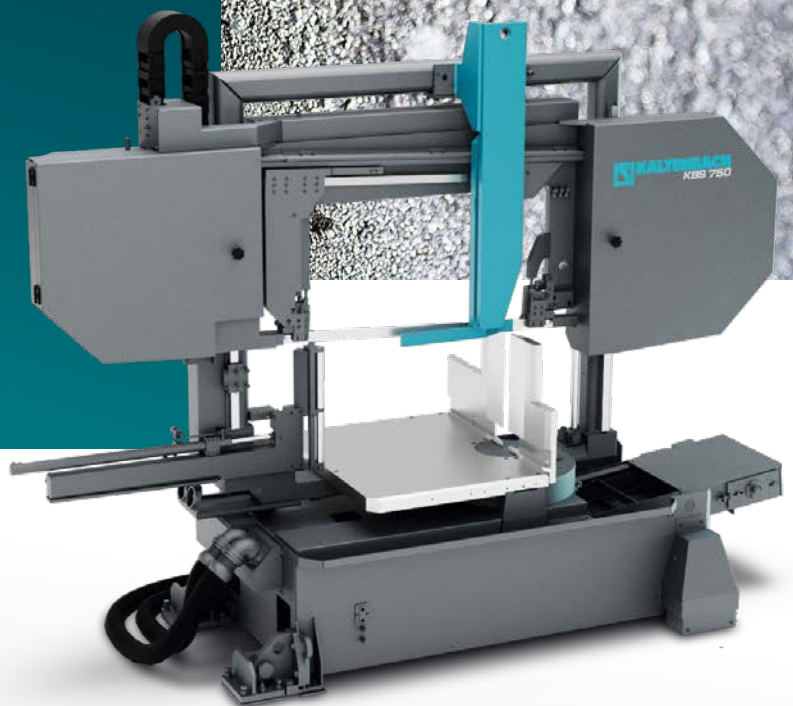

A highly versatile band saw for excellent steel products. Achieve the utmost flexibility in your factory. Powerful, automated and comfortable sawing of single beams, bundles or layers. Whatever your requirements, our team of experts can advise you on implementing the best solution.

- > SUSTAINABLE SOLUTIONS
- > LOW COST OF OWNERSHIP
- > EXCEPTIONAL RELIABILITY AND MAXIMUM UPTIME



KALTENBACH
PROMISES

BENEFITS AT A GLANCE

- > Long saw band life
- > Best cutting quality
- > Robust, low-vibration design
- > Perfect cutting results
- > Solid, reliable clamping system
- > Laser-assisted cutting edge visualization for manual cuts
- > Precise setting of cutting angle
- > Cutting pressure and slippage control
- > Rapid/working feed concept for shorter idle times

SOFTWARE FOR PROFESSIONALS

Powerful and user-friendly software packages

Machine software

Tailored to the unique features of the machine

In-house development

KALTENBACH develops its own steel fabrication software

Seamless compatibility

Hardware and software from one single source



Precise processing, high-quality end products, best cutting quality, very reliable system, maximum uptime.



High performance band sawing machines for the production of first class, sustainable steel products.

High-end cutting techniques

- HIGHLY VERSATILE BAND SAW
- MAXIMUM FLEXIBILITY
- OPTIMAL SAWING RESULTS

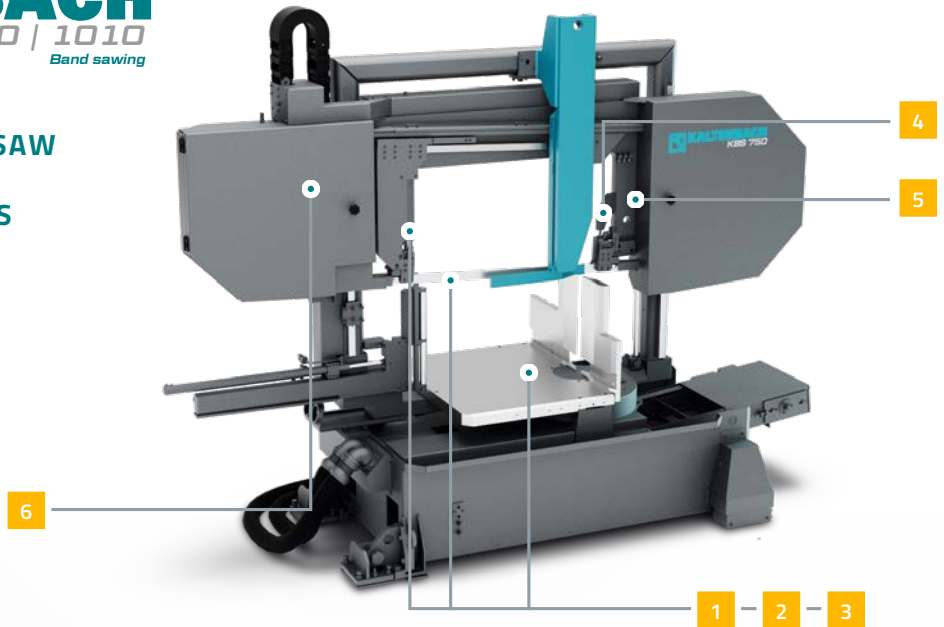

FEATURES



High level of production flexibility

- Powerful feed
- Hydraulic feed control with monitoring
- Fast and easy feed adjustment even during runtime

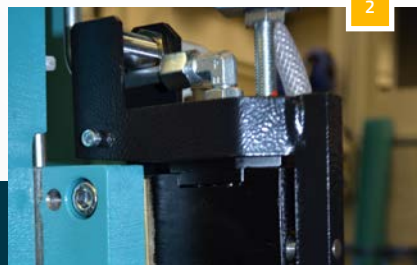

Increased uptime

- Automatic switching from rapid feed approach to pre-set feed rate
- Low idle times and higher machine utilization



Precise setting

- NC-controlled angle setting
- High quality cuts
- NC-standard enables highest reliability



Powerful and reliable clamping

- Horizontal and vertical clamping device
- Low vibrations for long saw band lifetime and low operating costs
- Cutting of material layers and bundles possible

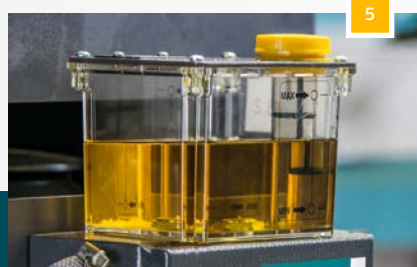

Long lifetime

- Minimum quantity lubrication
- Longer saw band lifetime
- No lubrications rest on the material



Available with material infeed gripper system

- Heavy feed gripper with horizontal hydraulic clamping device
- Positioning of lengths more than 3,000 mm via multiple stroke system

HARD FACTS

H T L U - O □

		KBS 750	KBS 1010
Working range max / min	mm	750 x 500 / 10x10	1,010 x 500 / 45 x 10
Drive power	kW	5.5	7.5
Cutting speed	m/min	15 - 100	15 - 120
Saw band feed	mm/min	0 - 300	0 - 400
Rapid feed and return	mm/min	2,500	
Saw band material		Bimetall	
Saw band dimensions (L x W x H)	m/min	41 x 1.3 x 6,990	41 x 1.3 x 7,470
Machine weight	kg	3,200	3,900
Machine dimensions (L x W x H)	mm	3,300 x 1,250 x 2,550	3,700 x 1,280 x 2,550



Saw drill combination

Possibility to combine with a drilling machine, resulting in a complete high performance processing system.



Efficient material handling

Designed to ensure an optimal process flow, and therefore the most effective processing of material in your production area.

HOME AT YOUR INDUSTRY

- > Automotive
- > Bridge Building
- > Machine Construction
- > Ship Building
- > Steel Fabrication
- > Steel Service Center
- > Transmission Towers

The KBS series is specially designed for light and heavy steel fabrication and service centers.



KALTENBACH



KALTENBACH GmbH + Co. KG
 Blasiring 4
 D-79539 Lörrach
 Germany

Tel: +49 7621 175 0
 E-Mail: info@kaltenbach.com

www.kaltenbach.com